

S型传感器 / S Type Force Sensor

LFS-06

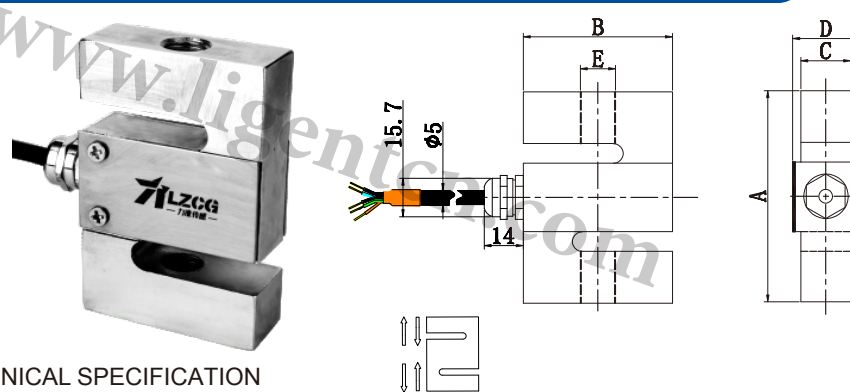

量程Capacity	A	B	C	D	E
10, 20, 30, 50, 75kg	63.5	50.8	12.7	19.1	M8*1.25/ 1/4-28
100, 200, 250, 300kg	76.2	50.8	19.1	25.4	M12*1.75/ 1/2-20
750, 1000, 1500kg	76.2	50.8	25.4	25.4	M12*1.75/ 1/2-20
2000, 3000, 5000kg	108	76.2	25.4	25.4	M18*1.5/ 3/4-16

TECHNICAL SPECIFICATION

量程 Capacity	0~10,20,50,75,100,200,300,500,750 1000,1500,2000,3000,5000kg	材质 Material	合金钢/不锈钢 Alloy steel / Stainless Steel
输出灵敏度 Rated Output	2.0/3.0 ± 10% mV/V	输出阻抗 Output Impedance	350 ± 3Ω
零点输出 Zero Balance	± 2 % F.S.	绝缘电阻 Insulation	≥ 5000MΩ/100VDC
非线性 Non-linearity	0.05% F.S.	使用电压 Recommended Excitation	5-10V
滞后 Hysteresis	0.05 % F.S.	最大使用电压 Maximum Excitation	15V
重复性 Repeatability	0.05 % F.S.	温度补偿范围 Compensated Temp Range	- 10 ~ 60 °C
蠕变 (30分钟) Creep (30min)	0.05% F.S.	工作温度范围 Operating Temp Range	- 20 ~ 80 °C
温度灵敏度漂移 Temp Effect on Output	0.05% F.S. / 10°C	安全超载 Safe Load Limit	150%
零点温度漂移 Temp Effect on Zero	0.05 % F.S. / 10°C	极限超载 Ultimate Load Limit	200%
输入阻抗 Input Impedance	385 ± 5 Ω	电缆线尺寸 Cable Size	Ø 5 x 3m
电缆线连接方式 Wire Connection	Ex + : 红 Red; Ex - : 黑 Black; S	ig + : 绿 Green ; Sig - : 白 White (拉为正, 压为负)	
主要应用 Applications	试验机、料斗秤、吊钩秤、铆钉机、焊接机等拉压力测试仪器以及自动化设备领域和测试领域 Mainly applied in tension and compression testing instruments and automatic equipments fields, such as testing instruments, hopper scales, lifting hook scales, insertion force test instruments, riveting machine, welding machine, and etc.		