

S型传感器 / S Type Force Sensor

LFS-01B

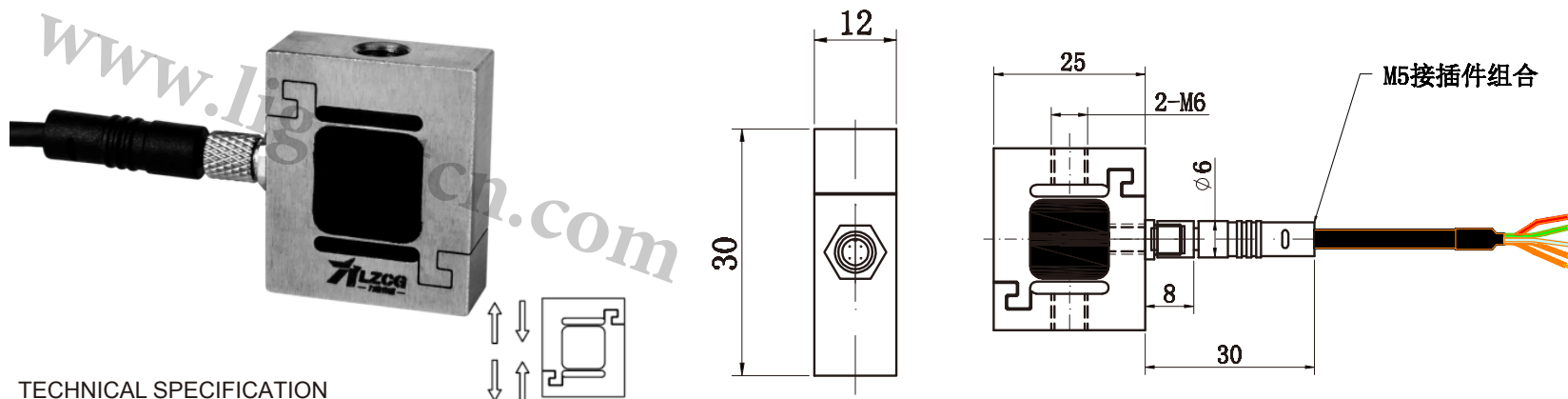

TECHNICAL SPECIFICATION

量程 Capacity	0~1,2,3,5,10,20,30,50,75,100kg	材质 Material	不锈钢 Stainless Steel
输出灵敏度 Rated Output	2.0 ± 10% mV/V	输出阻抗 Output Impedance	350 ± 3Ω
零点输出 Zero Balance	± 2 % F.S.	绝缘电阻 Insulation	≥ 5000MΩ/100VDC
非线性 Non-linearity	0.05 % F.S.	使用电压 Recommended Excitation	5 - 10V
滞后 Hysteresis	0.05 % F.S.	最大使用电压 Maximum Excitation	15V
重复性 Repeatability	0.05% F.S.	温度补偿范围 Compensated Temp Range	- 10 ~ 60 °C
蠕变 (30分钟) Creep (30min)	0.05 % F.S.	工作温度范围 Operating Temp Range	- 20 ~ 80 °C
温度灵敏度漂移 Temp Effect on Output	0.05 % F.S. / 10°C	安全超载 Safe Load Limit	150%
零点温度漂移 Temp Effect on Zero	0.05 % F.S. / 10°C	极限超载 Ultimate Load Limit	500%
输入阻抗 Input Impedance	385 ± 10Ω	电缆线尺寸 Cable Size	∅ 3 x 3m
电缆线连接方式 Wire Connection	Ex + : 红 Red; Ex - : 黑 Black; Sig + : 绿 Green ; Sig - : 白 White (压为正, 拉为负)		
主要应用 Applications	插拔力测试仪、铆钉机、焊接机、冷热压贴膜机、键盘按钮手感测试仪等拉压力测试仪器以及自动化设备领域和测试领域 Mainly applied in tension and compression testing instruments and automatic equipments fields, such as insertion force test instrument, riveting machine, welding machine, hot & cold lamination machine, feeling tester for keyboard switch, and etc.		