

环形测力传感器 / Ring Shaped Force Sensor

LFC-105

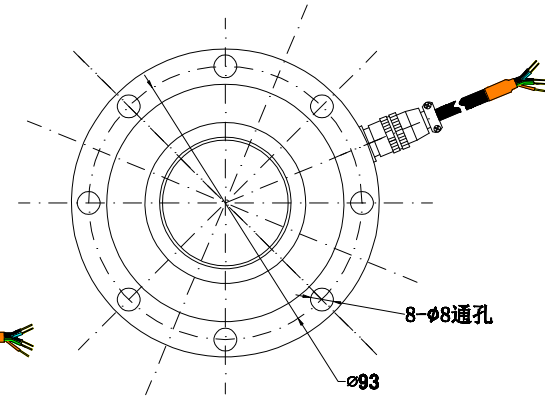
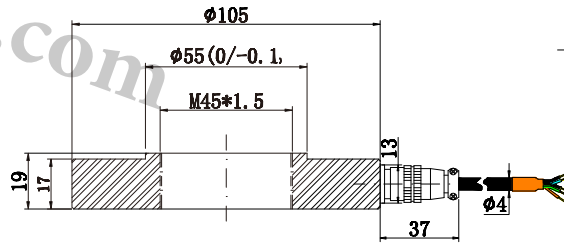
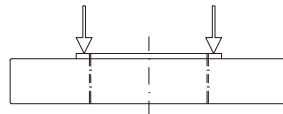

TECHNICAL SPECIFICATION

量程 Capacity	0~0.5,1,2,3,5t	材质 Material	不锈钢或合金钢 Stainless steel or Alloy steel
输出灵敏度 Rated Output	2.0 ± 10% mV/V	输出阻抗 Output Impedance	700 ± 3 Ω
零点输出 Zero Balance	± 2 % F.S.	绝缘电阻 Insulation	≥ 5000MΩ/100VDC
非线性 Non-linearity	0.1 % F.S.	使用电压 Recommended Excitation	5-10V
滞后 Hysteresis	0.1% F.S.	最大使用电压 Maximum Excitation	15V
重复性 Repeatability	0.1% F.S.	温度补偿范围 Compensated Temp Range	- 10 ~ 60 °C
蠕变 (30分钟) Creep (30min)	0.1 % F.S.	工作温度范围 Operating Temp Range	- 20 ~ 80 °C
温度灵敏度漂移 Temp Effect on Output	0.05 % F.S. / 10°C	安全超载 Safe Load Limit	150%
零点温度漂移 Temp Effect on Zero	0.05% F.S. / 10°C	极限超载 Ultimate Load Limit	200%
输入阻抗 Input Impedance	750 ± 5 Ω	电缆线尺寸 Cable Size	∅ 4 X 3m
电缆线连接方式 Wire Connection	Ex + : pin1 红 Red; Ex - : pin2 黑 Black; Sig + : pin3 绿 Green; Sig - : pin4 白 White		
主要应用 Applications	中空设计, 主要测量挤压力, 装配过盈力值检测和控制, 其它工业控制力值检测 Hollow design, Mainly measure and control extrusion ,interference force in assembling, and other force testing of industry field.		